

Static Excitation Equipment



ELECTROTEHNICA
ECHIPAMENTE ELECTRICE

Static excitation equipment for synchronous generators type EXC-GS

Operating principle

The equipment type EXC-GS provide the supply and protection of the synchronous generators excitation winding, having a rated excitation current of max. 600A.

These products represent a new generation of excitation equipment, utilizing programmable logic controllers and signal microprocessors (DSP) for accomplishing the control unit.

The excitation continuous current is obtained by means of a fully controlled thyristors rectifying bridge.

The equipment have 2 control regimes - AUTOMAT and MANUAL - having the possibility of switching-over between them. Due to the performances of the control and monitoring system, the commutation is made without excitation current shocks or terminal voltage.

The discharge of the synchronous generator is achieved by

the inverter operating of the rectifying bridge or by means of a thyristors static contactor and one resistor, when the thyristors bridge is blocked.

The static contactor also provides protection against overvoltages in the rotor circuit.

The following are provided:

- the control of the excitation current and the voltage at the generator terminals
- the discharge of the synchronous machines
- overcurrent protection of the excitation winding
- protection of the synchronous machine against the loss of excitation current
- stator overvoltage control

Application

The static excitation equipment are utilized in thermal stations and hydroelectric power plants.

Electrical diagram

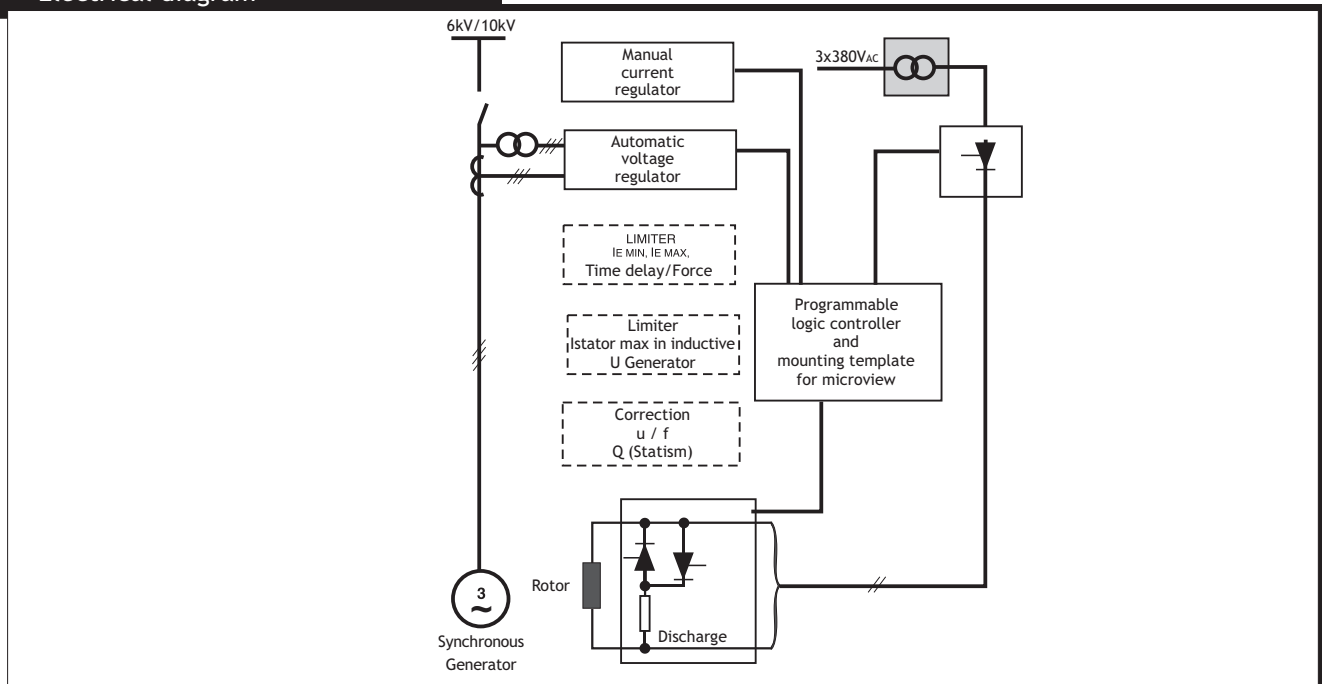

Technical parameters

Supply voltage	3x380V (+10%, -15%, 50Hz) or other voltage subject to application by means of a workhead transformer
AC supply auxiliary voltage	3x380VAc (or other voltage on demand)
DC supply auxiliary voltage	220Vdc (or other voltage on request)
Rated excitation current	maximum 600Adc (in accordance with the parameters of the synchronous generator)
Rated excitation voltage	maximum 400Vdc (in accordance with the parameters of the synchronous generator)

Voltage and current forcing factor	K=2 (or other values on demand)	
Control regimes	- AUTOMATIC	<ul style="list-style-type: none"> - terminals voltage control loop with reactive power correction - excitation current higher and lower limitation - temporary limitation of the excitation maximum current ($I^2 \times t$), followed by the forcing blocking for a controllable time period - limitation of the capacitive running, subject to active power - U/f correction with the generator not being connected to the system - limitation of the terminals maximum voltage
	- MANUAL	<ul style="list-style-type: none"> - excitation current control - excitation current higher and lower limitation - terminals maximum voltage limitation
Control accuracy	1% for both control regimes	
Discharge	<ul style="list-style-type: none"> - normal - by inverter operating of the bridge, followed by the temporary opening of the static contactor and the current turn-off through resistor - break-down - by static contactor and the current turn-off through resistor 	
Control mode	Local or Remote	
Protections against:	<ul style="list-style-type: none"> - lack of a supply phase (synchronization voltages) - excitation maximum current - lack of excitation current - high-speed fuses blow-out - opening, by accident, of the static contactor with the equipment being turned on - lack of ventilation (only for the variants with forced ventilation) 	
The failures are stored and can be visualized on the programmable logic controller display unit.		
Ventilation	- natural or forced (depending on the control)	
Overall dimensions (L x W x H)	800 x 800 x 2100mm	
Remark:		
The excitation equipment can enclose an additional cabinet, in which the starting resistor (with a value higher than 1 ohm) and the workhead transformer (with a power higher than 50kVA) are installed.		
The dimensions of the additional cabinet can be settled after reporting the technical parameters of the excitation current.		
Environmental conditions	<ul style="list-style-type: none"> - operating temperature: 0...40°C - storing temperature: -25...+70°C - operating maximum altitude: 1000m (above this altitude the equipment rated current will be lowered by 0.5% for each 100m) 	
Protection degree	IP21	

Choice / Denomination	Category code
<p>EXC-GS xxxV/xxxA-zz</p> <p> _____ Manufacturer's code _____ Rated excitation current _____ Rated excitation voltage </p>	30016102

Trading denomination	Generator power MW	Rated voltage V _{DC}	Rated current A _{DC}	Maximum overvoltage V _{DC}
EXC-GS 100V/215A	3	100	215	1000
EXC-GS 115V/225A	4	115	225	1000
EXC-GS 118V/290A	6	118	290	1000
EXC-GS 133V/252A	7,2	133	252	1000
EXC-GS 122V/457A	12	122	457	1000

Remarks:

- When placing a firm order, the following points must be mentioned:
- the power supply voltage for the excitation equipment
- the excitation rated current (A_{DC})
- the excitation rated voltage (V_{DC})
- the ceiling current (A_{DC})
- the ceiling voltage (V_{DC})
- the rated voltage, the rated current and the connections for the stator current and voltage reducers
- the rated voltage of the available accumulator battery.

Optional

The equipment can be optionally fitted with a serial interface (RS232 or RS485) by means of which the state logical variables and the value of the measured variables (voltages, currents, active power, reactive power aso) are remotely transmitted and remote controls are received.

Upon demand, the following can be changed: the voltage and / or current range, the protection degree, the temperature range.

Static excitation equipment for synchronous motors type EXC - MS

Operating principle

The equipment type EXC-MS ensure the supply and protection of the synchronous motors excitation winding, having a rated excitation current of maximum 600A.

These products represent a new generation of excitation equipment, by using programmable logic controllers and signal microprocessors (DSP) for accomplishing the control unit.

The excitation continuous current for the synchronous motor is obtained through fully controlled thyristors rectifying bridges.

The static contactor also provides protection against

overvoltages in the rotor circuit.

The following are provided:

- the control of the excitation current
- the control of the terminals voltage
- the control of the reactive power
- the discharge of the synchronous machine
- start-up on an outside resistor
- overcurrent protection of the excitation winding
- protection of the synchronous machine against the excitation current loss.

Applications

The equipment type EXC-MS are recommended for the following applications:

- Pumps destined to the discharge regulation in the hydrographic basins
- Water feed pumps
- Fans

- Air compressors
- Synchronous phase-modifier

They are utilized in the following fields: mining industry, metallurgical industry, irrigation systems, thermal stations and hydroelectric power plants.

Electrical diagram

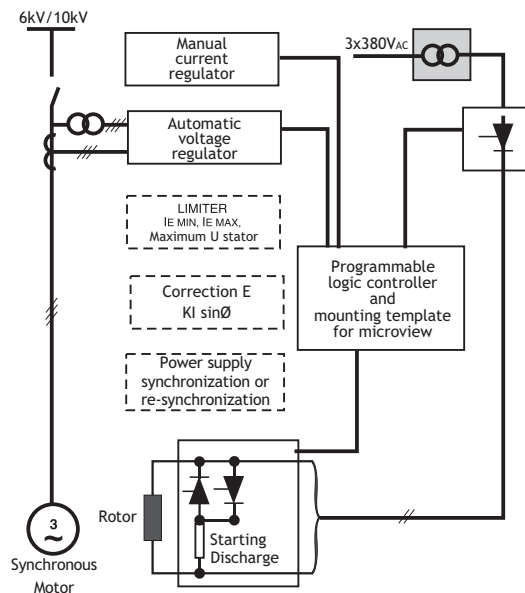

Technical characteristics

Supply voltage	3x380V (+10%, -15%, 50Hz) or other voltage subject to application by means of a workhead transformer
AC supply auxiliary voltage	3x380V _{AC} (or other voltage on demand)
DC supply auxiliary voltage	220V _{DC} (or other voltage on request)
Rated excitation current	maximum 600A _{DC} (in accordance with the parameters of the synchronous motor rotor)

Voltage and current forcing factor	K=2 (or other values on demand)
Rated excitation voltage	maximum 400Vdc (in accordance with the parameters of the synchronous motor rotor)
Control regimes	<ul style="list-style-type: none"> - AUTOMATIC <ul style="list-style-type: none"> - terminals voltage control loop with reactive power correction - excitation current higher and lower limitation - temporary limitation of the excitation maximum current ($I^2 \times t$), followed by the forcing blocking for a controllable time period - limitation of the terminals maximum voltage - MANUAL <ul style="list-style-type: none"> - excitation current control - excitation current higher and lower limitation - terminals maximum voltage limitation
Control accuracy	1% for both control regimes
Discharge	<ul style="list-style-type: none"> - normal - by inverter operating, followed by the temporary opening of the static contactor and the current turn-off through resistor - break-down - by static contactor opening and current turn-off through resistor
Control mode	Local or Remote
Protections against:	<ul style="list-style-type: none"> - lack of a supply phase - excitation maximum current - lack of excitation current - outrun synchronization time - high-speed fuses blow-out - opening, by accident, of the static contactor with the equipment turned on - lack of ventilation (only for the variants with forced ventilation)
The failures are stored and can be visualized on the programmable logic controller display unit.	
Ventilation	- natural or forced (depending on the control)
Overall dimensions (L x W x H)	800x800x2100mm
<p>Remark:</p> <p>The excitation equipment can enclose an additional cabinet, in which the starting resistor (with a value higher than 1 ohm) and the workhead transformer (with a power higher than 50kVA) are installed.</p> <p>The dimensions of the additional cabinet can be settled after reporting the technical parameters of the excitation current.</p>	
Environmental conditions	<ul style="list-style-type: none"> - operating temperature: 0...40°C - storing temperature: -25...+70°C - operating maximum altitude: 1000m (above this altitude the equipment rated current will be lowered by 0.5% for each 100m)
Protection degree	IP21

Choice / Denomination

Category code

EXC-MS xxxV/xxxA-zz

30016201

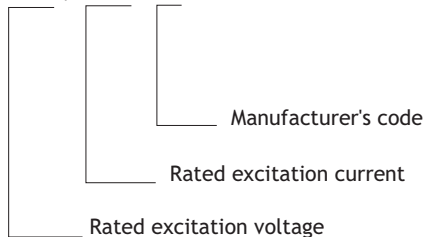

Trading denomination	Motor power MW	Rated voltage V _{DC}	Rated current A _{DC}	Maximum overvoltage V _{DC}
EXC-MS 35V/266A	0,63	35	266	1000
EXC-MS 45V/320A	1,25	45	320	1000
EXC-MS 144V/252A	1,6	144	252	1000
EXC-MS 30V/375A	1,8	30	375	1000
EXC-MS 183V/267A	1,8	183	267	1000
EXC-MS 31V/397A	2	31	397	1000
EXC-MS 36V/420A	2,5	36	420	1000
EXC-MS 87V/295A	3,2	87	295	1000
EXC-MS 35V/484A	3,6	35	484	1000
EXC-MS 40V/481A	4	40	481	1000
EXC-MS 55V/465A	5	55	465	1000
EXC-MS 69V/485A	5	69	485	1000
EXC-MS 94V/510A	10	94	510	1000

Remarks:

When placing a firm order, the following points must be mentioned:

- the power supply voltage for the excitation equipment
- the excitation rated current (A_{DC})
- the excitation rated voltage (V_{DC})
- the ceiling current (A_{DC})
- the ceiling voltage (V_{DC})
- the rated voltage, the rated current and the connections for the stator current and voltage reducers
- the rated voltage of the available accumulator battery.

Optional

The equipment can be optionally fitted with a serial interface (RS232 or RS485) by means of which the state logical variables and the value of the measured variables (voltages, currents, active power, reactive power aso) are remotely transmitted and remote controls are received.

Upon demand, the following can be changed: the voltage and / or current range, the protection degree, the temperature range.

The products presented in this document are liable of development any moment, the company reserving its right for amending the projects.

Static excitation equipment for synchronous machines type EXC-S

Operating principle

Excitation equipment type EXC-S are destined to provide the supply and protection of the excitation winding of the synchronous motors and generators, having an excitation current of max. 250A.

The excitation current for the synchronous machine is obtained by means of a fully controlled thyristors bridge which is designed with thyristor modules.

The equipment has two control regimes: AUTOMATIC and MANUAL.

The following are provided:

- Control of excitation current
- Discharge of the synchronous machine on an external resistance
- Start-up on an external starting resistance for synchronous motors
- Excitation winding overcurrent protection
- Synchronous machine protection against the excitation current lack

Applications

The static excitation equipment are recommended for the following applications:

- Power small plants
- Pumps destined to the discharge regulation in the hydrographic basins

- Water feed pumps
- Fans
- Air compressors

Electrical diagram

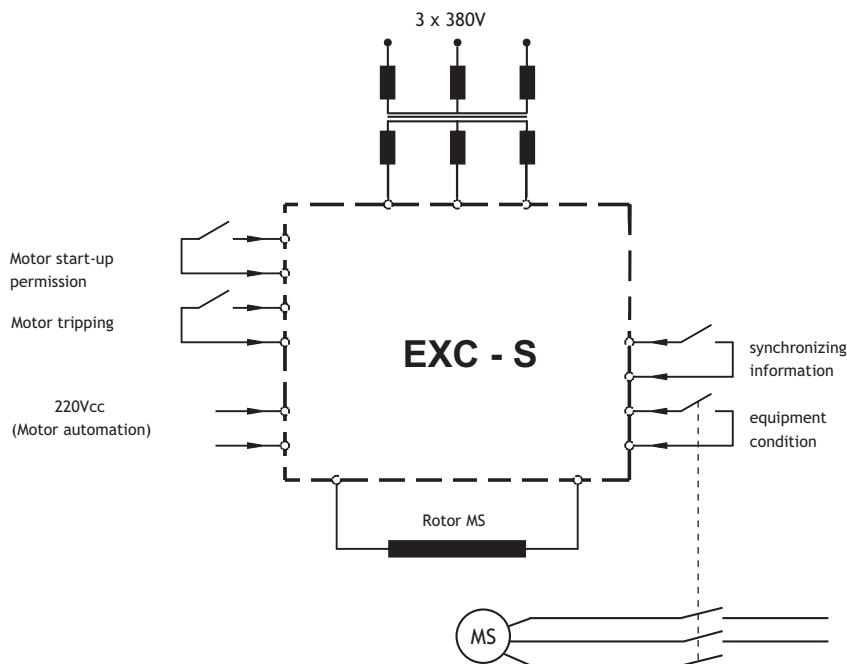

Technical parameters

Supply voltage	3x380V (+10%, -15%, 50Hz) or other voltage, depending on the application, by means of workhead transformer
Rated excitation current	150A _{dc} or 250A _{dc}
Maximum excitation voltage	400V _{dc}
Control regimes	AUTOMATIC control loop of the excitation current with lower and higher limitation MANUAL excitation current pre-setting
Control accuracy	2% for both control regimes
Protections	- lack of synchronization voltages - excitation maximum current - lack of excitation current
Ventilation	natural or forced
Overall dimensions (LxWxH)	400x500x600 mm
Environmental conditions	- operating temperature: 0...40°C - storing temperature: -25...+70°C - operating maximum altitude: 1000m (above this altitude the equipment rated current will be lowered by 0.5% for each 100m)
Protection degree	IP20

Choice/Denomination

Category code

EXC-S xxxV/xxxA-zz

30016101

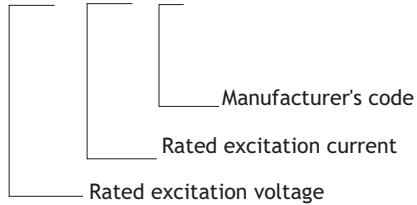

Trading denomination

Rated current

Dimensions mm

	A	L W H
	EXC-S 65V/150A	150
EXC-S 65V/250A	250	400x500x600
EXC-S 380V/150A	150	400x500x600
EXC-S 380V/250A	250	400x500x600

Other variants of powers, supply voltages, constructive variants are also available, on demand.

Static excitation equipment for synchronous generators with power higher than 12MW type EXC-P

Operating principle

The equipment type EXC-P ensure the supply and protection of the synchronous generators excitation winding. These products represent a new generation of excitation equipment, by using programmable logic controllers and signal microprocessors (DSP) for accomplishing the control unit.

The excitation continuous current is obtained through fully controlled thyristors rectifying bridges.

The equipment are endowed with 2 control regimes - AUTOMATIC and MANUAL - with the possibility of switching-over between them. Due to the performances of the control and monitoring system, the commutation is made without excitation current or terminal voltages hocks.

The discharge of the synchronous generator is achieved by

the inverter operating of the rectifying bridge or by means of a thyristors static contactor and one resistor, when the thyristors bridge is blocked.

The static contactor also provides protection against overvoltages in the rotor circuit.

The following are provided:

- the control of the excitation current and the voltage at the generator terminals
- the discharge of the synchronous machine
- overcurrent protection of the excitation winding
- protection of the synchronous machine against the excitation current loss
- limitation of stator overvoltage

Applications

The static excitation equipment are utilized in thermal stations and hydroelectric power plants.

Electrical diagram

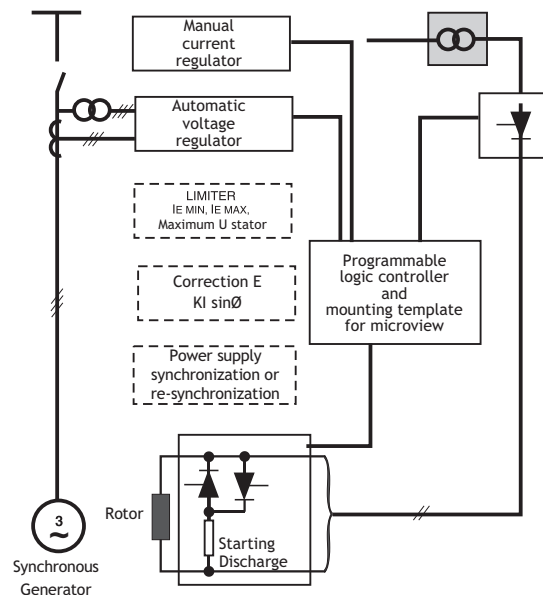

Technical characteristics

Supply voltage	3x380V (+10%, -15%, 50Hz) or other voltage subject to application by means of a workhead transformer
AC supply auxiliary voltage	3x380V _{AC} (or other voltage on demand)
DC supply auxiliary voltage	220V _{DC} (or other voltage on request)
Rated excitation current	in accordance with the parameters of the synchronous generator rotor
Rated excitation voltage	in accordance with the parameters of the synchronous generator rotor
Voltage and current forcing factor	K=2 (or other values on demand)

Control regimes	- AUTOMATIC	- terminals voltage control loop with reactive power correction - excitation current higher and lower limitation - temporary limitation of the excitation maximum current ($I^2 \times t$), followed by the forcing blocking for a controllable time period - limitation of the capacitive running, subject to active power - U/f correction with the generator not being connected to the system - limitation of the terminals maximum voltage
	- MANUAL	- excitation current control - excitation current higher and lower limitation - terminals maximum voltage limitation
Control accuracy		1% for both control regimes
Discharge		- normal, by inverter operating of the bridge, followed by the temporary opening of the static contactor and the current turn-off through resistor - break-down, by static contactor and the current turn-off through resistor
Control mode		Local or Remote
Protections against:		- lack of a supply phase (synchronization voltages) - excitation maximum current - lack of excitation current - high-speed fuses blow-out - opening, by accident, of the static contactor with the equipment being turned on - lack of ventilation (only for the variants with forced ventilation)
The failures are stored and can be visualized on the programmable logic controller display unit.		
Ventilation		- natural or forced (depending on the control)
Overall dimensions (L x W x H)		according to variant
Environmental conditions		- operating temperature: 0...40°C - storing temperature: -25...+70°C - operating maximum altitude: 1000m (above this altitude the equipment rated current will be lowered by 0.5% for each 100m)
Protection degree		IP21

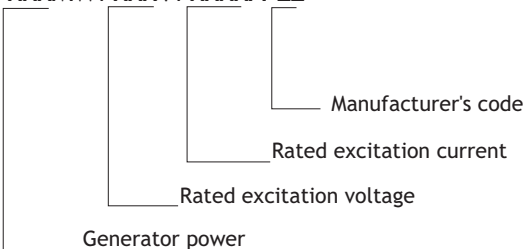
Choice / Denomination	Category code
<p>EXC-P xxxMW/xxxV/xxxxA-zz</p>  <p>Generator power</p> <p>Rated excitation voltage</p> <p>Rated excitation current</p> <p>Manufacturer's code</p>	30016103

Trading denomination	Dimensions mm		
	L	W	H
EXC-P 25MW/170V/730A	2400	800	2300
EXC-P 27MW/200V/2300A	4800	800	2300
EXC-P 60MW/200V/1400A	2400	800	2300
EXC-P 65MW/242V/924A	2400	800	2300
EXC-P 135MW/400V/1320A	2400	800	2300
EXC-P 160MW/265V/2200A	4000	800	2300
EXC-P 330MW/400V/2600A	4800	800	2300

Remarks

- The excitation equipment for hydro power plants can operate subject to the voltage variation and the supply frequency, within larger limits (voltage $0.4...1.2U_n$, frequency 30...100Hz).
- The equipment can be endowed, on demand, with automatic circuit breakers installed between the DC converter and the generator excitation winding.
- For the equipment that are supplied from the generator terminals, a circuit is provided in order to start the generator from the central battery.
- When placing a firm order, the following points must be mentioned:
 - the power supply voltage for the excitation equipment (V_{CA})
 - the excitation rated current (A_{DC})
 - the excitation rated voltage (V_{DC})
 - the ceiling current (A_{DC})
 - the ceiling voltage (V_{DC})
 - the rated voltage, the rated current and the connections for the stator current and voltage reducers
 - the rated voltage of the available accumulator battery.

Optional

The equipment can be optionally fitted with a serial interface (RS232 or RS485) by means of which the state logical variables and the value of the measured variables (voltages, currents, active power, reactive power aso) are remotely transmitted and remote controls are received.

Upon demand, the following can be changed: the voltage and / or current range, the protection degree, the temperature range.